

CONEXIÓN DE ACERO AL CARBON ASTM A234 WPB

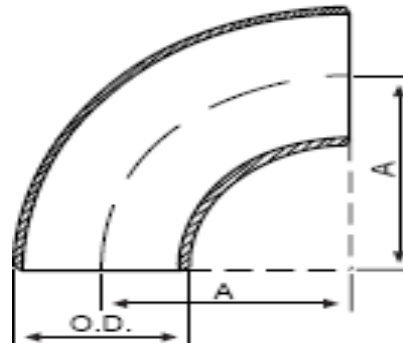

CODO 90° RADIO CORTO

DN	DIAMETRO	CENTRO A	ESPESOR
pulg.	EXTERIOR	EXTREMO	SCH 40
	A BISEL (O.D)	A	
	(mm)	(mm)	(mm)
1	33.4	25.4	3.38
1 1/4	42.2	31.7	3.56
1 1/2	48.3	38.1	3.68
2	60.3	50.8	3.91
2 1/2	73.0	63.5	5.16
3	88.9	76.2	5.49
4	114.3	101.6	6.02
5	141.3	127.0	6.55
6	168.3	152.4	7.11
8	219.1	203.2	8.18
10	273.0	254.0	9.27
12	323.9	304.8	10.30
14	355.6	356.0	11.10
16	406.4	406.0	12.70



PHONE: 866 6350600/6341284/6342619/6342620 WWW.PERFITUBOS.COM