

CONEXIÓN DE ACERO AL CARBON ASTM A234 WPB

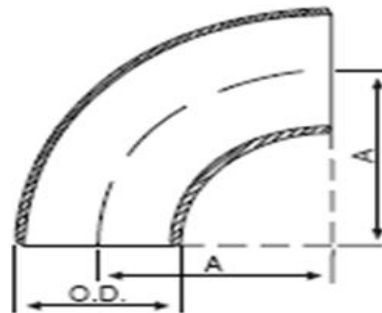

CODO 90° RADIO LARGO

DN	DIAMETRO	CENTRO A	ESPESOR DE PARED	
			SCH 40	SCH 80
pulg.	EXTERIOR	EXTREMO		
	A BISEL (O.D)	A		
	(mm)	(mm)	(mm)	(mm)
1/2	21.3	38.1	2.77	3.73
3/4	26.7	38.1	2.87	3.91
1	33.4	38.1	3.38	4.55
1 1/4	42.2	47.6	3.56	4.85
1 1/2	48.3	57.1	3.68	5.08
2	60.3	76.2	3.91	5.4
2 1/2	73.0	95.2	5.16	7.01
3	88.9	114.3	5.49	7.62
4	114.3	152.4	6.02	8.56
5	141.3	190.5	6.55	9.53
6	168.3	228.6	7.11	10.97
8	219.1	304.8	8.18	12.70
10	273.0	381.0	9.27	15.10
12	323.9	457.2	9.53	17.50
14	355.6	533.4	9.53	19.10
16	406.4	609.6	9.53	21.40
18	457.2	685.8	9.53	-
20	508.0	762.0	9.53	-
24	609.6	914.4	9.53	-
30	762.0	1143.0	9.53	-
36	914.0	1372.0	9.53	-



PHONE: 866 6350600/6341284/6342619/6342620 WWW.PERFITUBOS.COM